

Chunky Cheese Build Guide Rev. 2008-08-04

The Chunky Cheese is a slightly-modified version of the discontinued Big Cheese fuzz pedal.

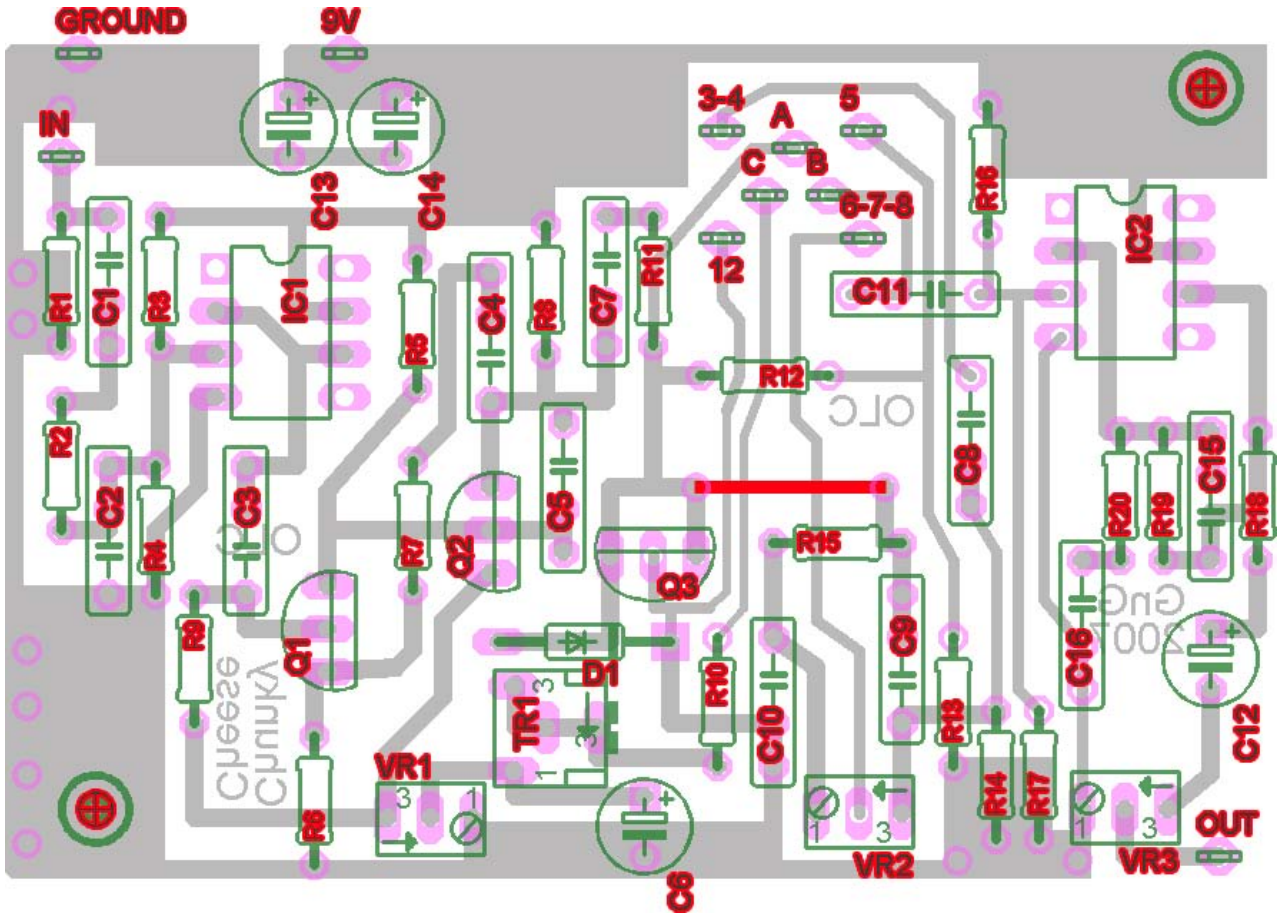

Table of Contents

Table of Contents.....	1
PCB Layout.....	2
Parts List.....	3
Step 1: Populating the Board.....	5
Step 2: Stompbox Internals.....	10
Step 3: Enclosure Parts Assembly.....	15
Step 4: Wiring the Enclosure Hardware.....	17
Wiring the Chunky Cheese.....	19
Troubleshooting.....	24

PCB Layout

The following graphic shows the layout of the printed circuit board. Take a moment to become familiar with the board, its orientation, and the location of major components before proceeding.



Parts List

The following list shows each part of the kit. Go over the list and ensure that you received all the parts. The values in the Code column show the color codes for the resistors and the number codes for the capacitors.

Please download this: http://www.olcircuits.com/documents/resistor_and_capacitor_charts.pdf

In many cases, you will have extra resistors (usually, one extra per value). This is done as a service to you.

Schematic #	Part Value	Code/Notes
Resistors		
R1	4.7 MΩ	Yellow Purple Green (this resistor is tan in color)
R2	1 KΩ	Brown Black Black Brown
R3	680 KΩ	Blue Grey Black Orange
R4	680 KΩ	Blue Grey Black Orange
R5	100 KΩ	Brown Black Black Orange
R6	470 Ω	Yellow Purple Black Black
R7	470 KΩ	Yellow Purple Black Orange
R8	10 KΩ	Brown Black Black Red
R9	100 KΩ	Brown Black Black Orange
R10	1 KΩ	Brown Black Black Brown
R11	47 KΩ	Yellow Purple Black Red
R12	47 KΩ	Yellow Purple Black Red
R13	47 KΩ	Yellow Purple Black Red
R14	47 KΩ	Yellow Purple Black Red
R15	47 KΩ	Yellow Purple Black Red
R16	680 KΩ	Blue Grey Black Orange
R17	680 KΩ	Blue Grey Black Orange
R18	470 Ω	Yellow Purple Black Black
R19	33 KΩ	Orange Orange Black Red
R20	15 KΩ	Brown Green Black Red
TR1	1 KΩ trim	
VR1	1 KΩ Linear Taper – Fuzz	B1K
VR2	100 KΩ Linear Taper – Tone	B100K
VR3	10 KΩ Audio Taper – Volume	A10K
LED Resistor	10k Ω	Brown Black Black Red

Schematic #	Part Value	Code/Notes
Capacitors		
C1	47 nF	473
C2	1.5n	152
C3	47 nF	473
C4	47 nF	473
C5	47 pF	470 or 47
C6	4.7 μ F polarized electrolytic	
C7	47 nF	473
C8	6.8 nF	682
C9	2.2 nF	222
C10	10 nF	103
C11	47 nF	473
C12	4.7 μ F polarized electrolytic	
C13	22 μ F polarized electrolytic	
C14	22 μ F polarized electrolytic	
C15	100 pF	101
C16	100 nF	104
Semiconductors		
D1		1N4148/1N914 silicon diode for polarity protection
Q1, Q2, Q3		2N3904 transistor
U1		TL071/TL081 Operational Amplifier
U2		TL071/TL081 Operational Amplifier
Hardware		
Aluminum enclosure		Hammond 1590BB style
DC jack		Black plastic with chrome nut
LED		Color varies with kit/order
9 volt battery snap		Red=positive, black=negative
LED bezel clip		Black plastic ring with notches
LED bezel ring		Black plastic ring
Heat shrink tubing		Insulators for LED leads
Knobs (4)		Quarter inch plastic
3PDT stomp switch		
¼" Stereo input jack		
¼" Stereo/mono input jack		
Transistor sockets		
3P4T rotary switch		

Step 1: Populating the Board

The PCB is a single sided board that holds all the components with the exception of the potentiometers, LED, jacks, DC adaptor and the stomp switch.

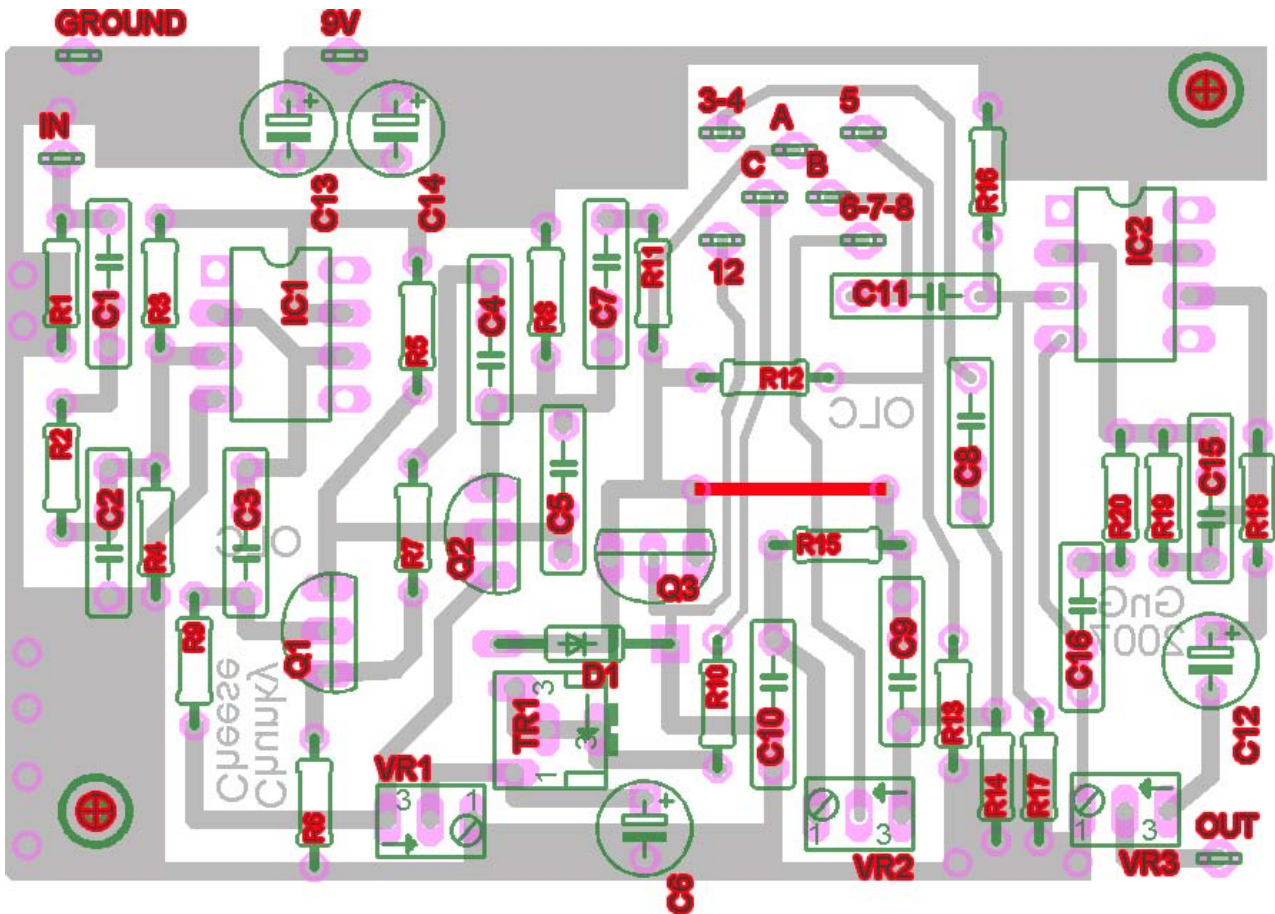

The Unpopulated PCB

Insert components on the blank side (the side without any copper traces) through the appropriate holes. Take your time as you figure out the correct holes for the components. You may find it useful to identify “landmarks” in the hole patterns—for example look for the closest transistor which will be three holes close together in a vertical strip. Having a landmark makes it easier to get your bearings. Don’t be afraid to turn the board over and look at the copper traces and pads, but remember you’re looking at the reverse image...

For each component, bend the wires on the other side flat to help hold the component in place while you solder. Nip off the ends of the wires after the solder has hardened so that there is no wire left sticking out of the solder blob.



Note: The pictures shown in this build guide may depict components that differ slightly in color and packaging or size from the components that are included in your kit. This is due to variations if components and vendors. Be sure to double check the codes of components (color bands for resistors, codes for capacitors, etc.) against those listed in the Parts List section earlier in this document to ensure you working with the correct value.

Jumpers

The PCB requires one jumper wire (RED line above R15). Cut a wire of the appropriate length and solder it to the PCB as shown.

NOTE: You can also use a resistor lead to do this. When you trim the excess after soldering resistors, you'll have plenty.

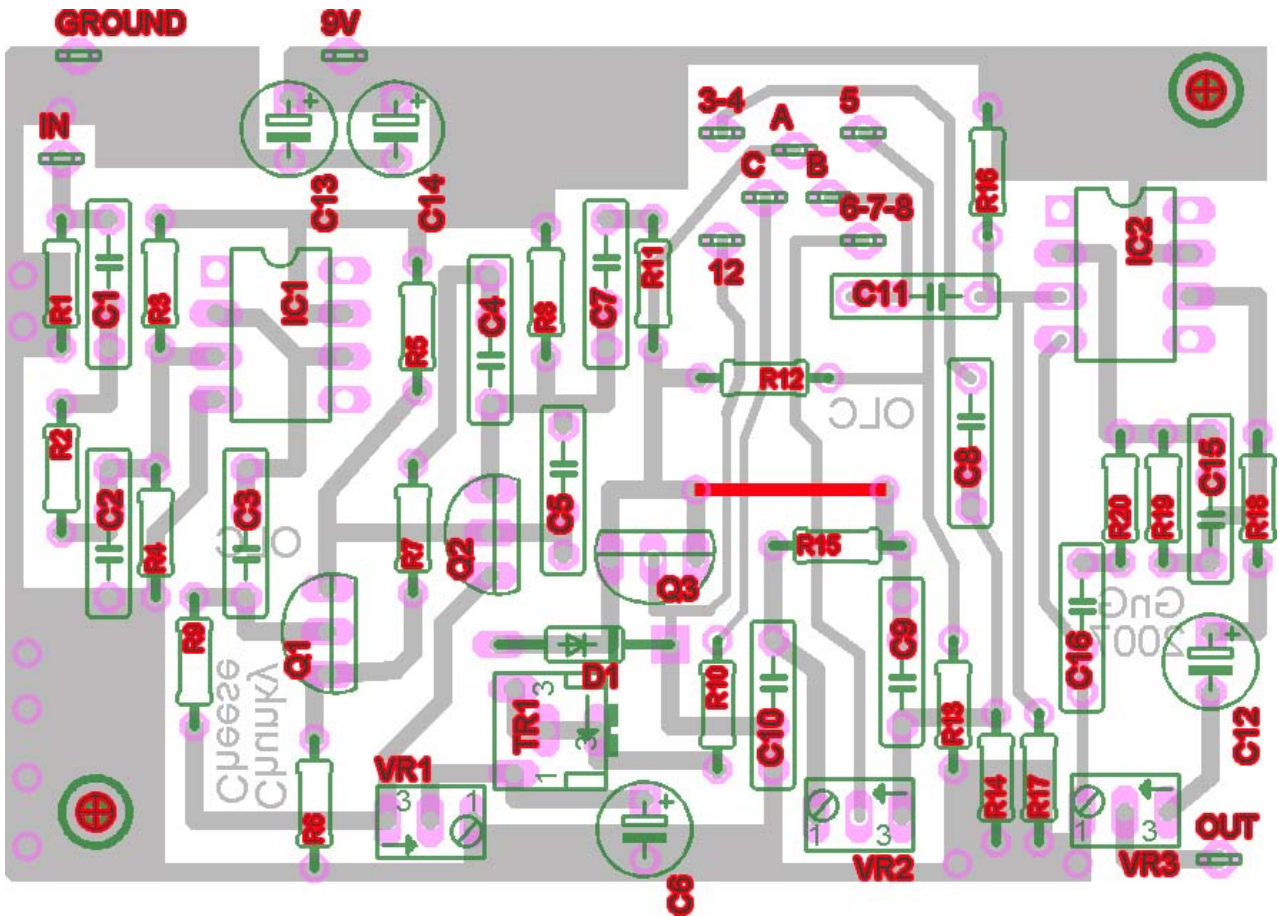

Resistors

Start with the resistors (don't worry about the potentiometers or trimmer pots in this step, just do the fixed resistors). Carefully check each resistor against the color band code in the parts list. You may also find it helpful to you have your digital multimeter on and set to Ohms for this step. After you check and verify the color codes of a resistor, and before you solder them to the board, double-check the value with your meter. Note that resistors do not have polarity (i.e. there is no positive or negative side) so you can insert them in either direction.

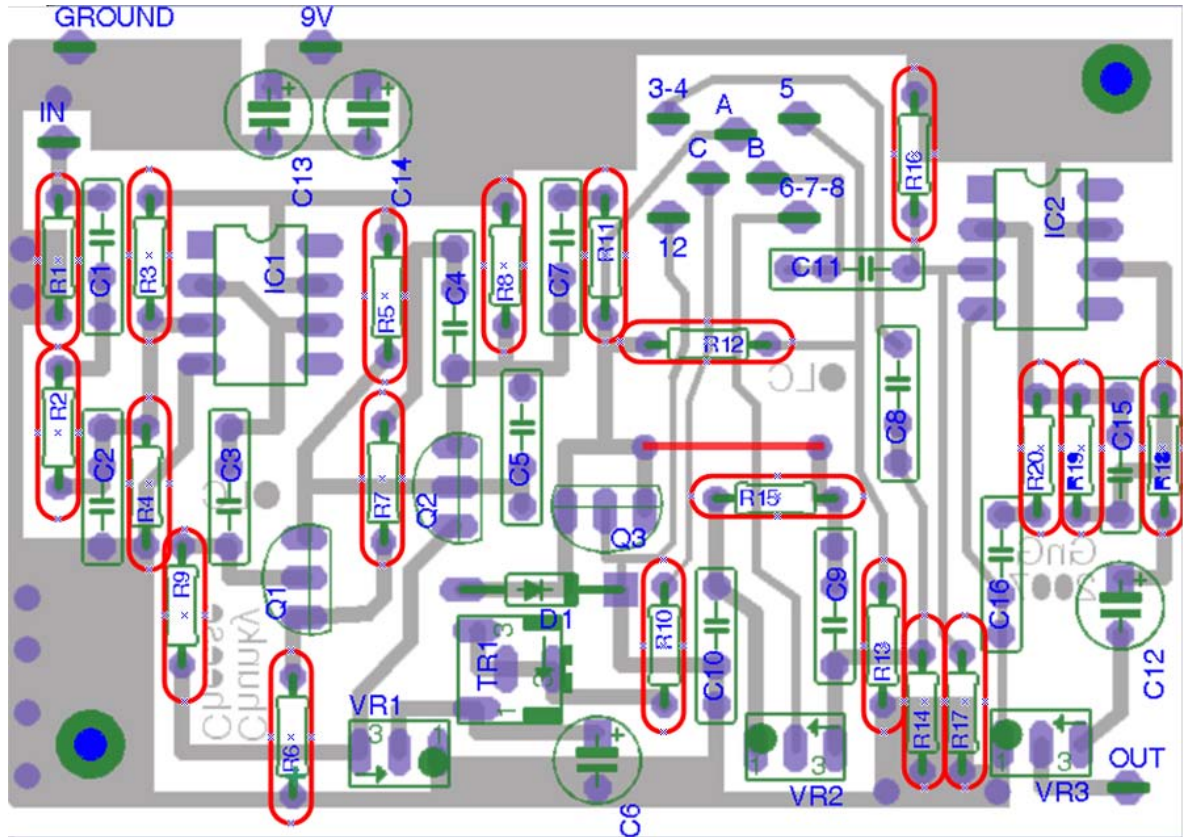

Capacitors

The circuit uses four polarized electrolytic capacitors. These are C6, C12, C13, and C14. Polarized capacitors have a positive and a negative side—look at the capacitor to see which lead is which. Install the polarized caps in the correct orientation according to the layout diagram. You will see a + sign for the hole where the positive lead should go. Polarized caps are shown in green. All other capacitors are non-polarized—it doesn't matter which side is which. These are shown in red. As with the resistors, check each capacitor's code value against those listed in the Parts List to ensure you have the right value. If your multimeter has the ability to measure capacitors it would be a good idea to double check them before solder them in.

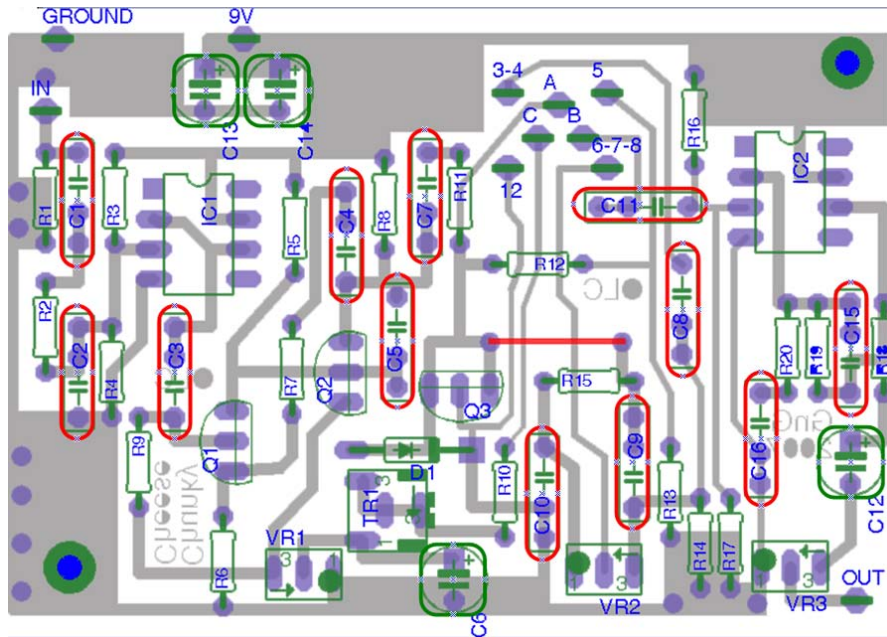

Semiconductors

Install the diode, the two opamps and the three transistors. Each of the semiconductors is polarity sensitive. Install the diode with the stripe as shown, the transistors oriented as shown, and the opamps with the notch in the case aligned with the notch shown on the PCB.

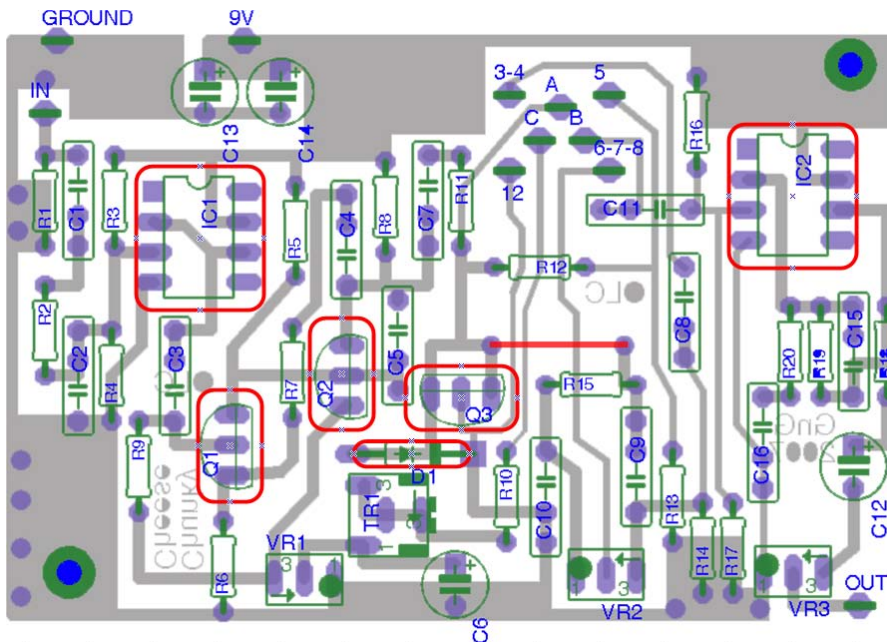

Time to Double Check

Now that the PCB components are mounted, it is a good time to double-check your work. You'll find that most difficult-to-solve problems involve the PCB. You'll want to check for:

- Components are mounted in the wrong holes
- Polarity is reversed (polarized capacitors, ICs, transistors, diodes)
- Cold solder joints (i.e. the solder was not sufficiently heated/spread to make contact between the component lead and the copper pad)
- Unsoldered components: its easy to overlook one or two leads.
- Solder bridges: places where solder has flowed between two or more connectors that shouldn't be connected.

The PCB is done for now. Set it aside for now and we'll start working on the enclosure.

Step 2: Stompbox Internals

If you are new to building pedals, there may be a bit of mystery involved in how some of the hardware components work. How does the AC adaptor jack disconnect the battery when you plug in an adaptor? What are the pin numbers on potentiometers?

This section explains how each of the hardware parts in your kit work and covers:

- The AC adaptor jack and plug
- The input and output jacks
- The potentiometers

If you are already familiar with these parts, you can skip ahead to Step 3 but it make your build easier if you quickly refresh yourself on the basic anatomy of a stompbox.

The AC adaptor Jack

The AC adaptor not only accepts a power supply jack—it is also part of the power switching. The most common type used in pedals is the 2.1 mm, tip-negative jack and plug arrangement. This is what you'll find on typical commercial pedals like those from Boss, Ibanez, etc. and is what is included with your Officially Licensed Circuits kit.

Here are the views and pin-outs for the standard three-prong 2.1 mm AC adaptor jack:

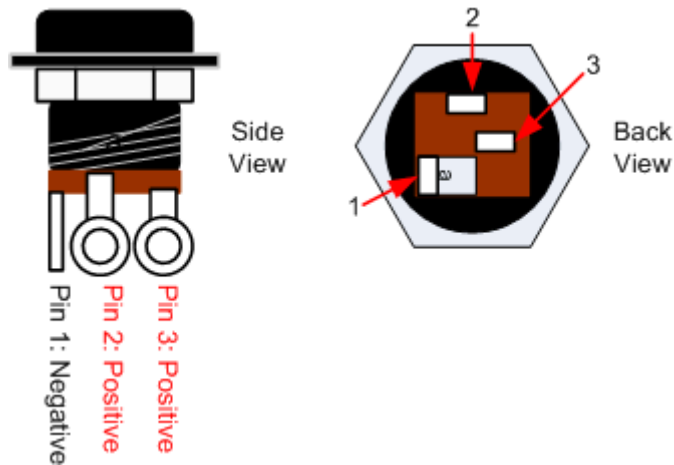

And here's what the plug looks like:

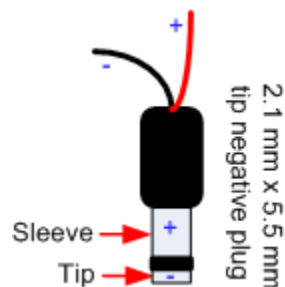

But if the power supply (battery or adaptor) only needs positive and negative connections, why the three-lug jack? That's the magic of the jack: one lug is for negative, and two are for positive. When you insert your AC adaptor plug, the jack automatically disconnects one of the positive lugs for you. When there is no plug inserted, pin 2 and 3 are connected together internally in the jack. When you insert the jack into the plug, the connection between pins 2 and 3 is broken, the sleeve (+) of the plug is connected to pin 2, and the tip of the plug (-) is connected to pin 1.

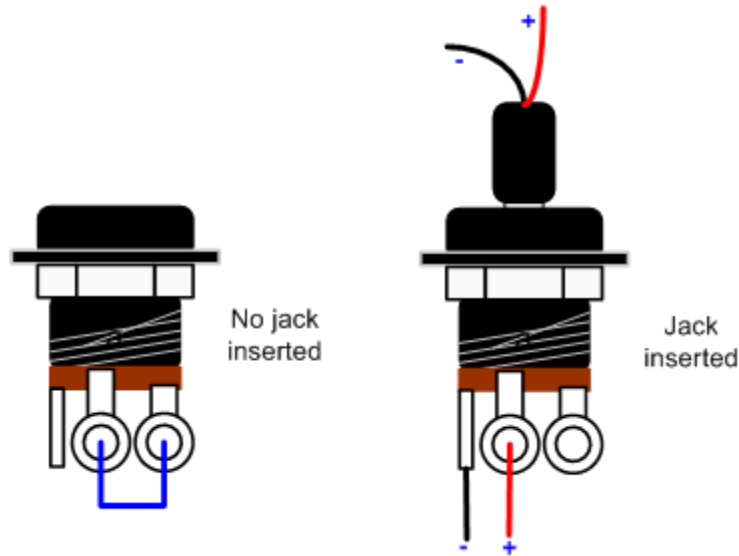

About the Input and Output Jacks

Your kit comes with two Marshall-style stereo ¼" jacks. These are for the pedal input and output.

Lugs bent down to save space and make it easier to identify which side to use

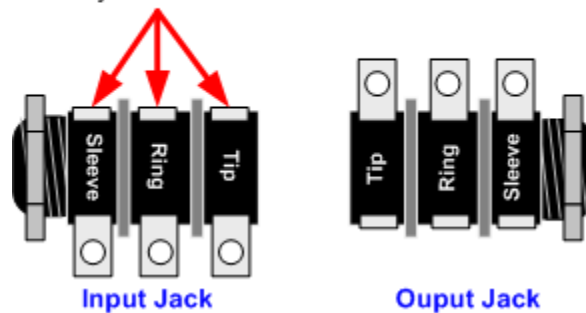

¼" Jacks

But they also serve another purpose. In addition to using the stereo input jack to plug your guitar into, the circuit will also use it as an on/off switch. But how does this work? You've probably already guessed that it uses the same mechanism as we discovered in our review of the AC adaptor jack: a three prong jack. The ¼" input jack on a pedal is actually a stereo jack—that's why it has three lugs.

Inserting a plug makes a connection between the Ring and the Sleeve

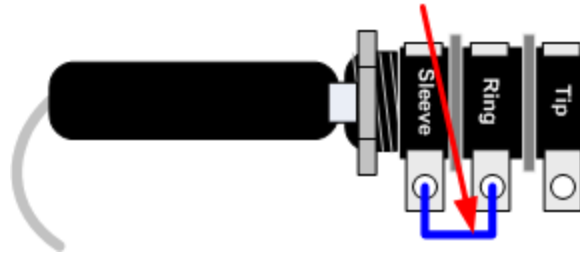

The Input Jack

The Tip carries the signal, and the ring and sleeve act as a switch and carry the ground. When you have nothing inserted in the jack, there is no connection between the ring and the sleeve. However, as soon as you plug in your guitar (or any 1/4" plug) the ring and sleeve lugs are connected. This is the “switch” used to disconnect the battery when you unplug your guitar.

All Powered Up and Ready to Go

So now we have the basic power switching circuit in place. Time to add the battery. We want the battery to be switched out of circuit if we insert an AC adaptor (no point in draining the battery if we are using an adaptor!). We also want the battery switched out of circuit when we remove the plug from the pedal’s input jack.

Using the switching we’ve learned about, we can construct a circuit which accomplishes this. First, here’s what it looks like when there is not AC adaptor plug inserted—the AC adaptor plug connects the two positive terminals, as shown by the blue line below:

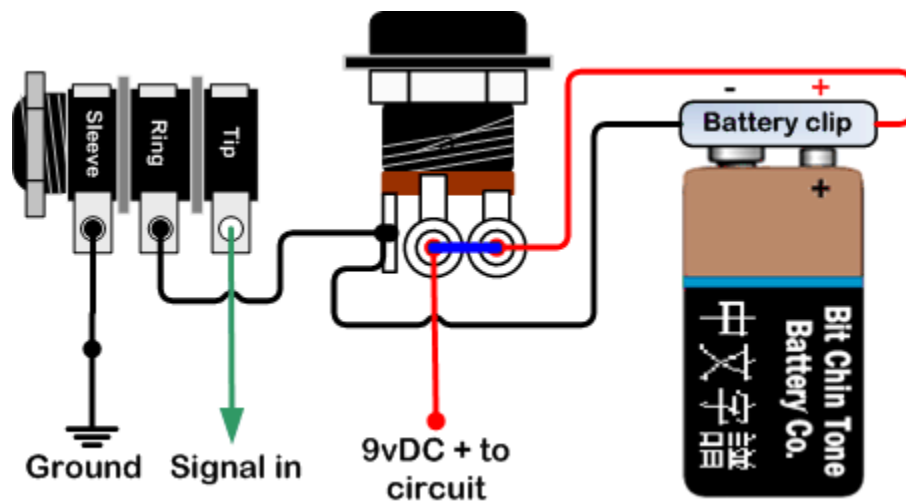

Complete Power Wiring, Running on Battery Power

Now when we insert an AC adaptor plug, we want the battery to be disconnected. By inserting the plug, we break the connection between the AC adaptor jack's two positive terminals which essentially removes the battery from the circuit. Here's how that is wired up:

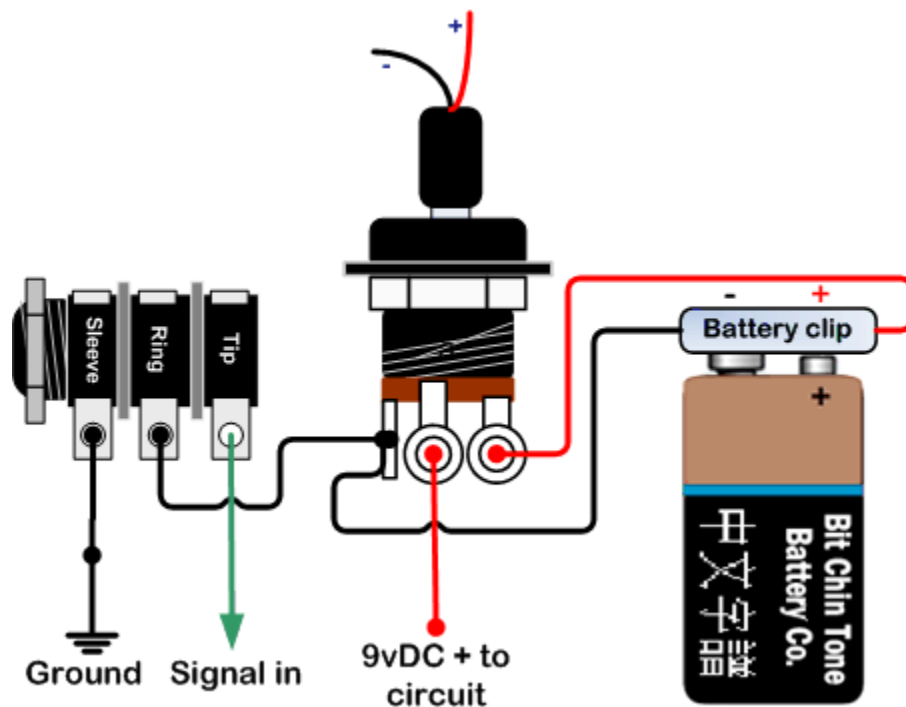

Complete Power Wiring, Running on AC Adaptor

All About Potentiometers

Your kit includes at least one potentiometer, maybe more. A potentiometer (pot for short) is a fairly simple part—it is a variable resistor, and it used to control things like volume and tone. The first thing you need to know about pots is the code for reading the type and value.

The two main types of pots are either Audio/Logarithmic taper or Linear taper. Taper refers to how the rotation of the knob affects the curve of the resistance. Audio/Logarithmic tapers account for the non-linear way that our ears perceive sound—it is not a straight linear curve as you rotate the shaft. Linear pots on the other hand are just that—the resistance changes in a purely linear fashion as you turn the shaft.

Which leads us to the coding scheme you'll need to know about regarding pots. A typical pot will not be labeled “100 k ohm Linear Taper”. Instead, a code is used. “A” signifies an audio/logarithmic taper and “B” signifies a linear taper. The letter code is followed by the resistance value. Here are some examples:

A100K: 100 k ohm audio/logarithmic taper pot

B100k: A 10 k ohm linear taper

B1M: 1 Meg ohm linear taper

The other important thing to know about pots is the pin numbering scheme. Here's what a pot looks like in a schematic:

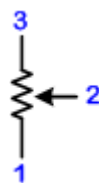

Potentiometer Schematic

And here's how those schematic pin numbers map to the actual hardware:

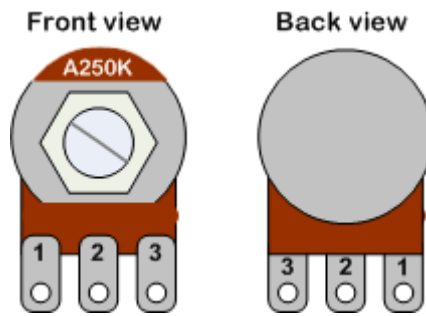

Potentiometer Pin Numbers

Finally, most pots will have a small metal tab that protrudes from the top of the pot. This is used to anchor the pot in enclosures where the tab hole has been drilled. Before installing the pot in your enclosure, use a pair of needle-nose pliers to break off this tab.

Wrapping it Up

Now that you've learned the basics of the hardware, it is time to move on to the next step and actually start assembling and wiring your pedal.

Step 3: Enclosure Parts Assembly

Now that you have most of the PCB done, its time to start work on the enclosure. If you ordered an un-drilled enclosure, drill the appropriate holes for the jacks, the DC adaptor, LED and stomp switch. If you received a drilled enclosure, you're ready to go. Install the pots first, then the LED and the power jack. Then move on to the stomp switch and the input and output jacks.

Note that the input and output jacks are oriented opposite of each other. You can move the potentiometers to any arrangement you like, but if you change the locations, you'll need to adjust the wiring arrangements shown later in the Build Guide.

Remove the Potentiometer Tabs

Potentiometers have a small metal tab that protrudes upward in the same direction as the shaft. This tab is used to anchor the pot in panel enclosures that have a special hole drilled for it. Your OLC kit doesn't use this tab, so you'll have to snap it off before mounting the pot. See the diagram below.



Remove the tabs from each of the five potentiometers before mounting them on the enclosure.



Note: The pictures and graphics below regarding the enclosure are shown from the perspective of looking into the back of the pedal (i.e. the screw-holes for the enclosure bottom are facing up).

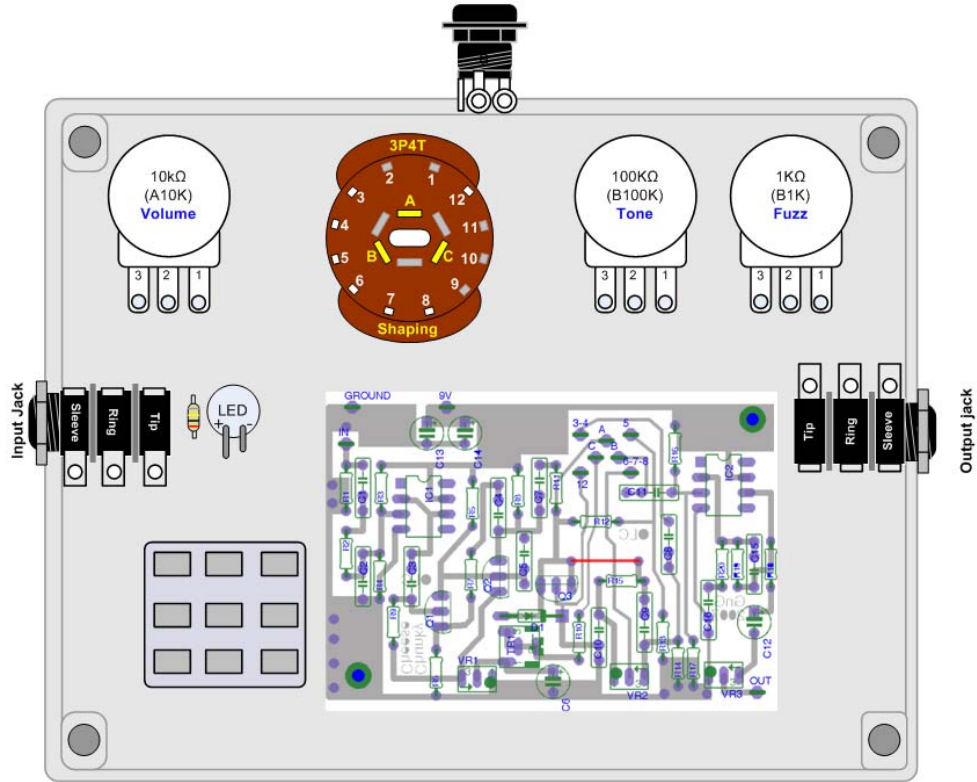

Step 4: Wiring the Enclosure Hardware

Now that all the parts are physically installed in the box, you can start the wiring process. In this step, you'll wire up the input and output jacks, the switch, LED, battery clip and AC adaptor connector.

You have two goals in this step: to correctly wire all the parts together exactly as shown, and to keep your wires to the minimum length necessary to fit in the box. Why short lengths? First off, shorter wires reduce noise—the longer the wire, the greater the chance that it can act as an antenna for picking up stray radio frequency or other interference. This is especially true in effects that are high gain by nature.

The second reason to keep your wire lengths short is that it makes it easier to end up with a professional looking build that doesn't have a bunch of wires compressed between pots and the boards, wires that get folded over and looped by battery, etc. Each wire also represents an opportunity for mechanical failure. Each time physical stress is put on a wire, the wire itself and the solder joints it connects to can weaken. During the build process you will be putting parts in, maneuvering them around the enclosure, fixing problems, and other things. Later on when the pedal is done, you'll be opening the case to change batteries. All these things can lead to physical stress on the wires—the shorter the length, the less chance that the wire will be exposed to stress.

Of course, at this point you probably just want to get the thing working. So try your best on wire lengths, but at the same point don't obsess over it.

Preparing the LED

The LED has a positive lead and a negative lead. The positive lead is the longer of the two. You'll need to wire a series resistor between the positive 9v source of the circuit and the positive lead of the LED—this is to protect the LED from too much current, and subsequent burnout.

Your kit includes two resistor values for you to choose from. The stock 4.7 Ω value results in a brighter LED, but may lead to a popping sound when switch the circuit on and off. For this reason, you may want to consider using the alternative 15k Ω value instead.

Preparing the LED for assembly into the enclosure takes a little bit of work, but it isn't difficult. The following diagram and steps lead you through the process.

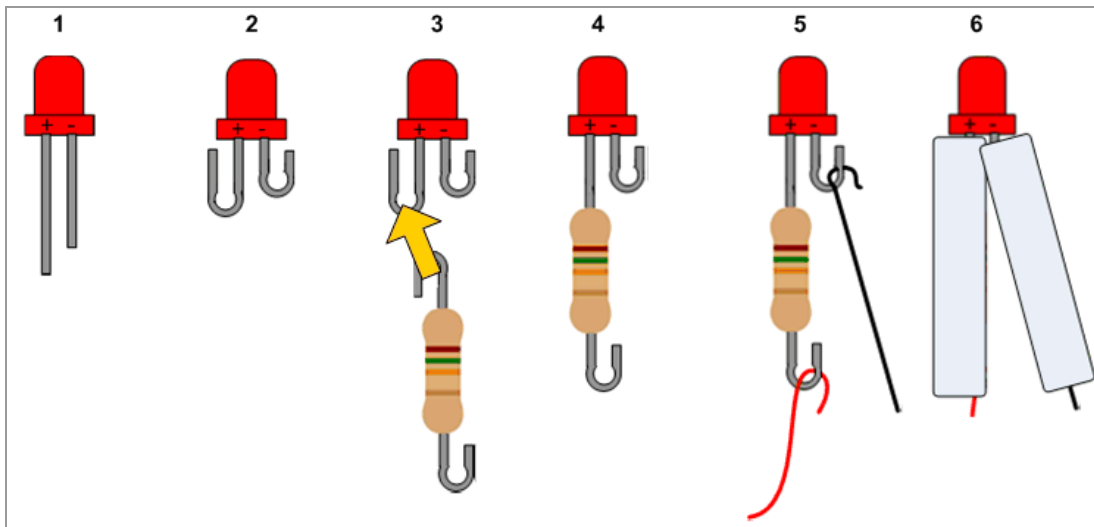

LED Assembly

1. Notice the LED has a long lead and a short lead. The long lead connects to positive in the circuit.
2. Use needle-nose pliers to carefully form two lugs with the leads. Keep the positive one longer than the negative one to help remember which side is which polarity-wise.
3. Choose the resistor you want to use. The 4.7k Ω resistor will provide a brighter LED but may lead to popping when you press the stomp switch. We recommend that you use the 15k Ω part to avoid this problem. As with the LED, make small lugs on each side of the resistor.
4. Solder one of the resistor lugs to the positive side of the LED.
5. Solder a length of red wire to the other log on the resistor. Solder a length of black wire on to the negative side of the LED.
6. Use the included heat-shrink tubing to protect the LED legs from short out. Slip it on to the wire and turn the LED upside down to let gravity hold the tubing in place. Then use a lighter to carefully and slowly shrink the tubing. Don't heat it to long or you will burn the tubing and/or the wires. You'll know you've done it right when the tubing is shrunk down to a tight fit over each side of the LED.

Your LED assembly is now completed and ready to be snapped into the enclosure using the included bezel.

Wiring the Chunky Cheese

Hardware Wiring

Wire the hardware in the enclosure according to the following diagram. Note that the lines in the diagram do not represent the actual lengths of wire to use—as mentioned above, try to keep your lead lengths to a minimum.

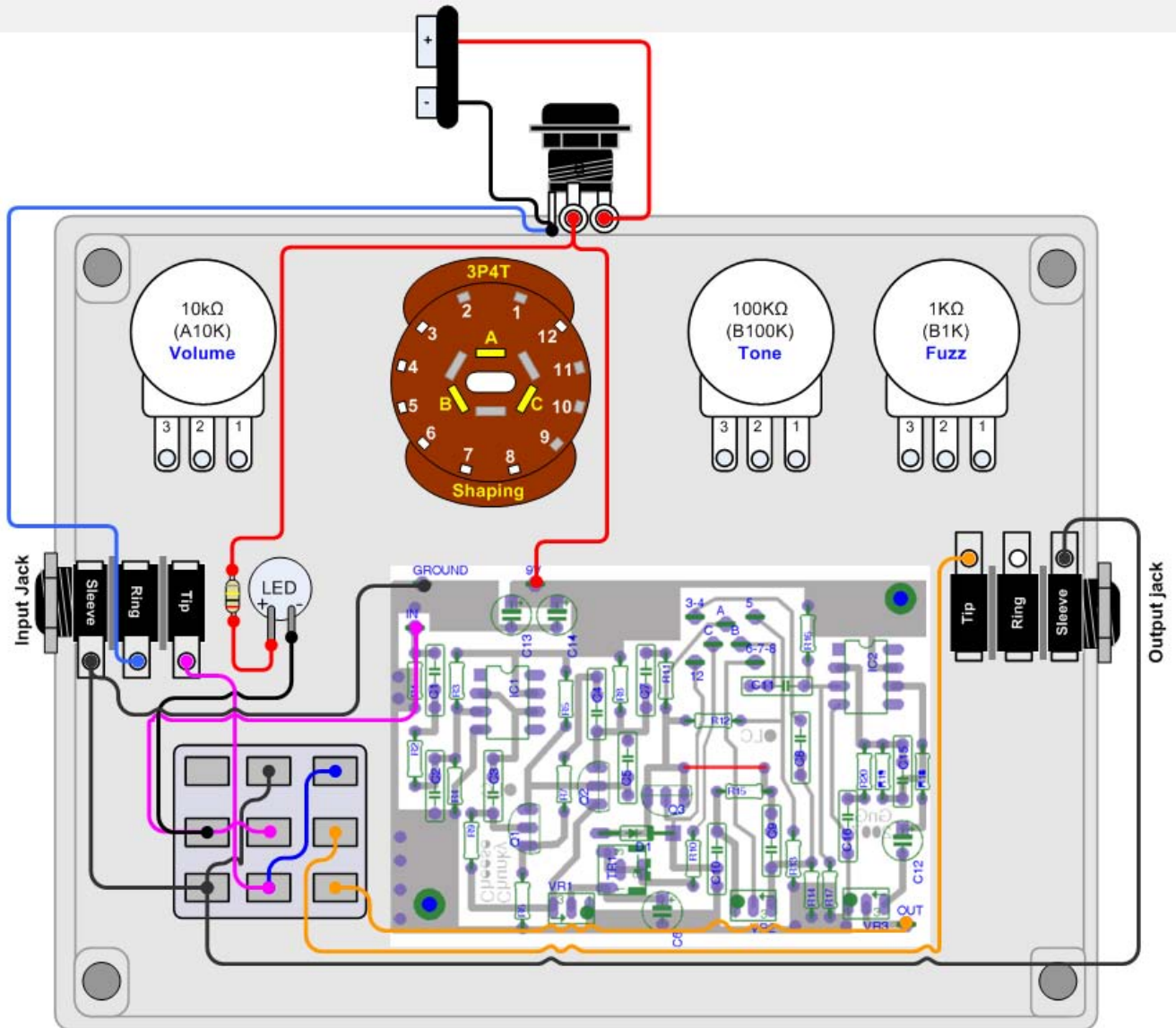

Wiring the Potentiometers

In this step, you'll wire all of the connections from the PCB to the potentiometers. Make sure you pay special attention to the pin numbers on the pots.

To make it easier, try these tips:

1. Use a permanent marker to label the back of each pot. For example, "B" for bass, "V" for volume and so on. Be sure to check the potentiometer value before labeling them. Adding these letters can help save a world of hurt later when you realize you wired the wrong pot to the wrong part of the PCB!
2. Wire one pot at a time. Measure the amount of wire you'll need to reach the board from that particular pot and leave a little excess. For your measurements, take into account whether the pot wires will need to go under the PCB or on top. (Under makes for a cleaner looking build.) Solder the three wires to the pot.
3. Before you solder the wires to the PCB, use some extra heat-shrink tubing to organize the 3-wires into bundles.
4. Take your time and work carefully when inserting the pot wires into the PCB. The PCB holes are quite small, and you want to be sure that you don't leave any stray strands of wire sticking out on the top (non-copper) part of the board.
5. Please download this: http://www.olcircuits.com/documents/olc_soldering101_guide.pdf

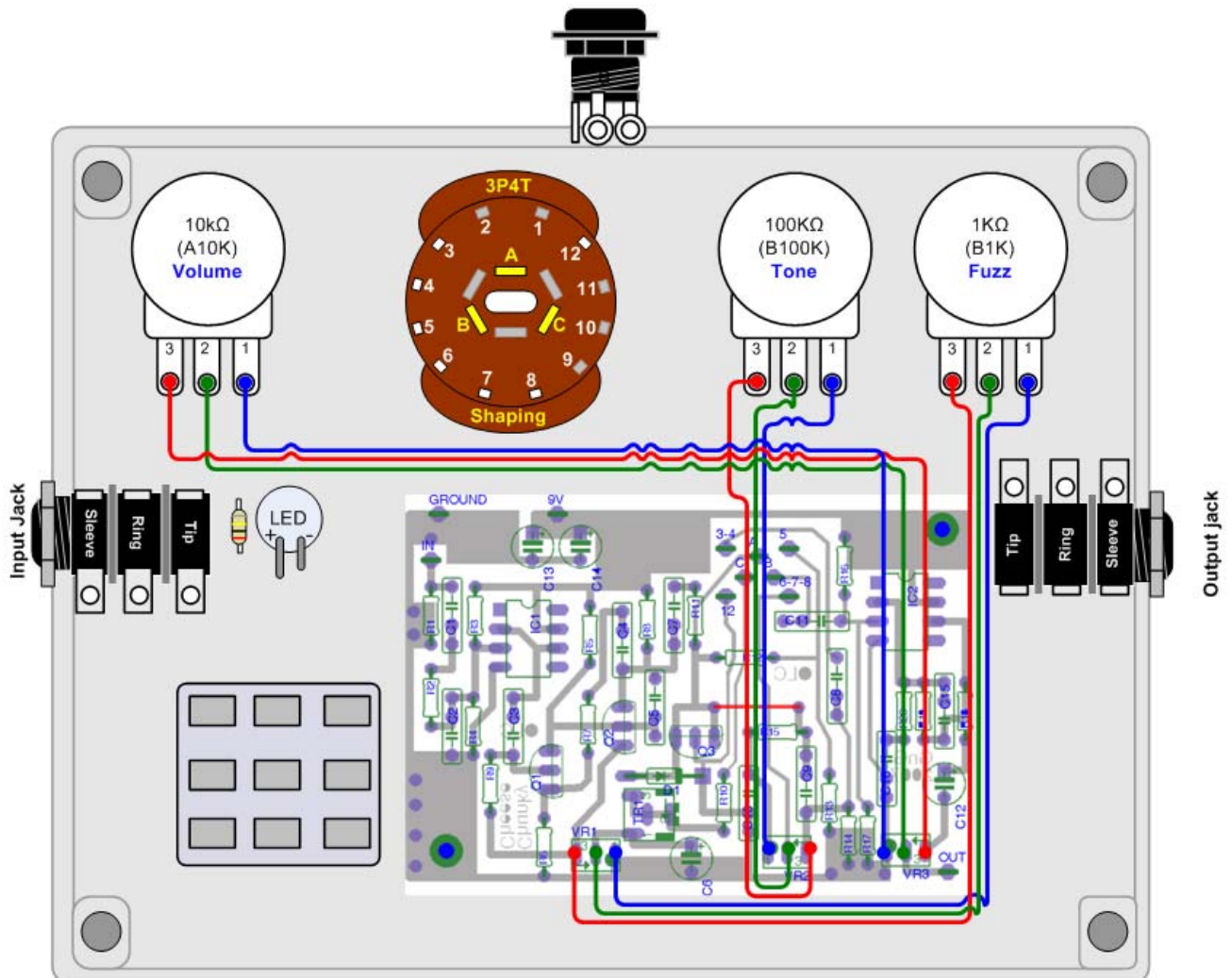

Wiring the Shaping Switch

The following diagram shows the pin numbers on the back of the 3P4T Shaping switch. The pins shown in gray are not used. The ones in yellow and white are used.

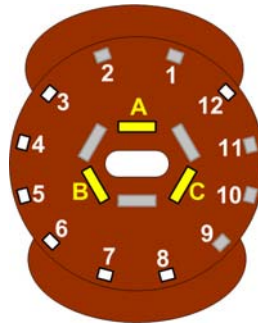

First, solder wires to connect pins A, B and C.

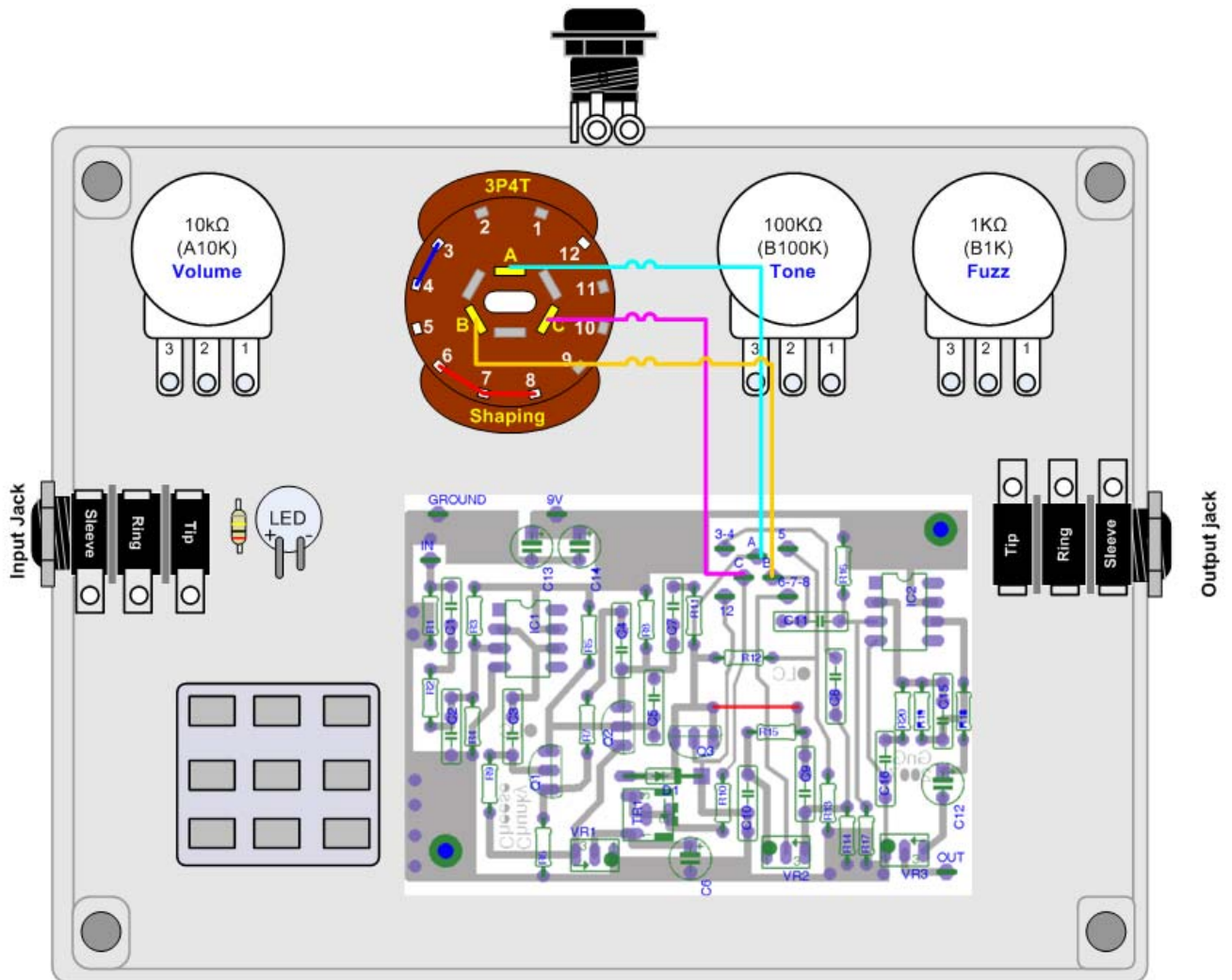

Next, connect wires to the remaining switch pins, matching up pins 3, 4, 5, 6, 7, 8 and 12 with the appropriate holes on the PCB.

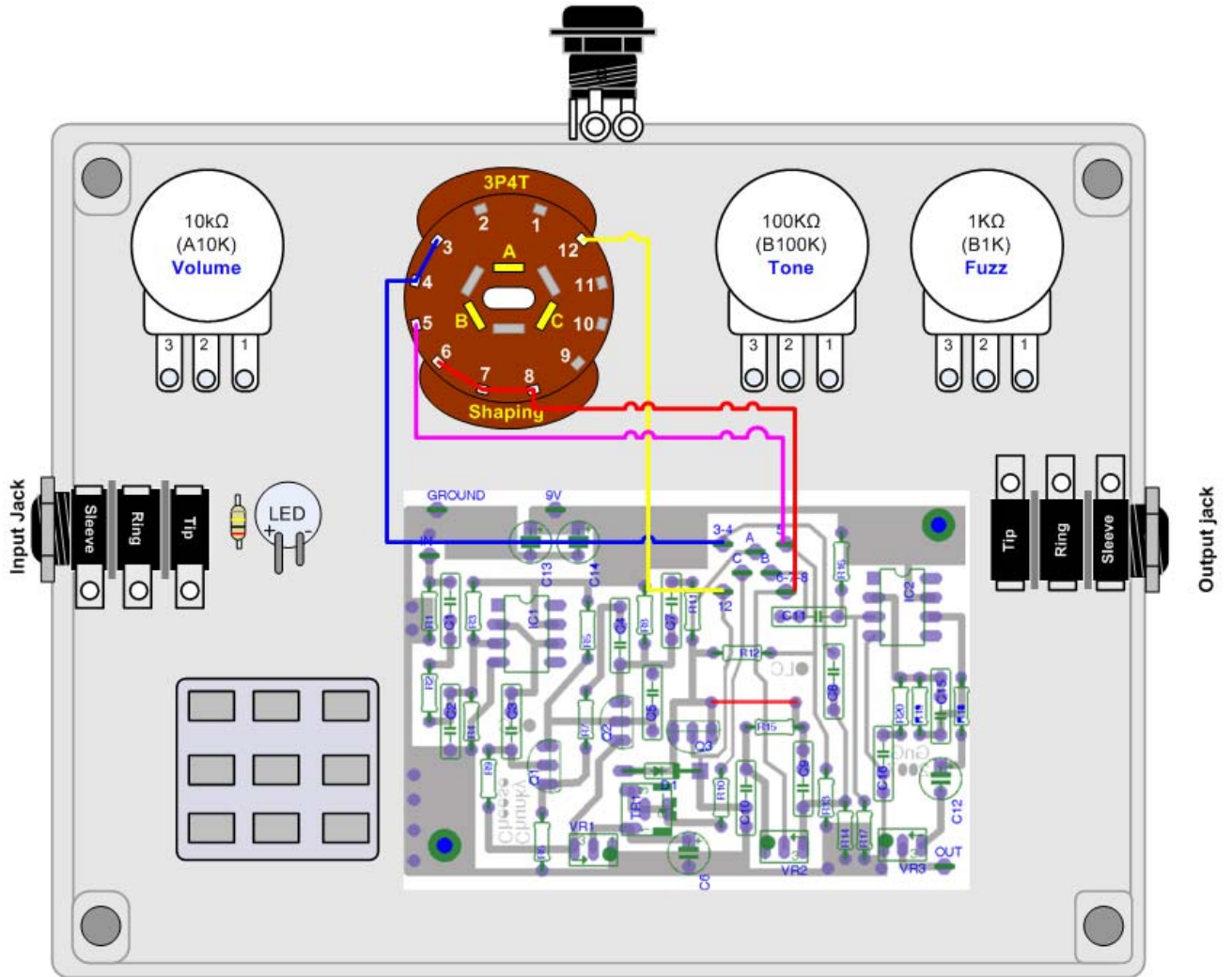

From pad "6-7-8" on the PCB: Strip enough insulation from your wire and solder it across pins 6, 7, and 8 on the switch.
From pad "3-4" on the PCB: Strip enough insulation from your wire and solder it across pins 3 and 4.

Final Check

As your last step, you'll want to double-check each connection you've made. Use the following complete wiring diagram as a checklist:

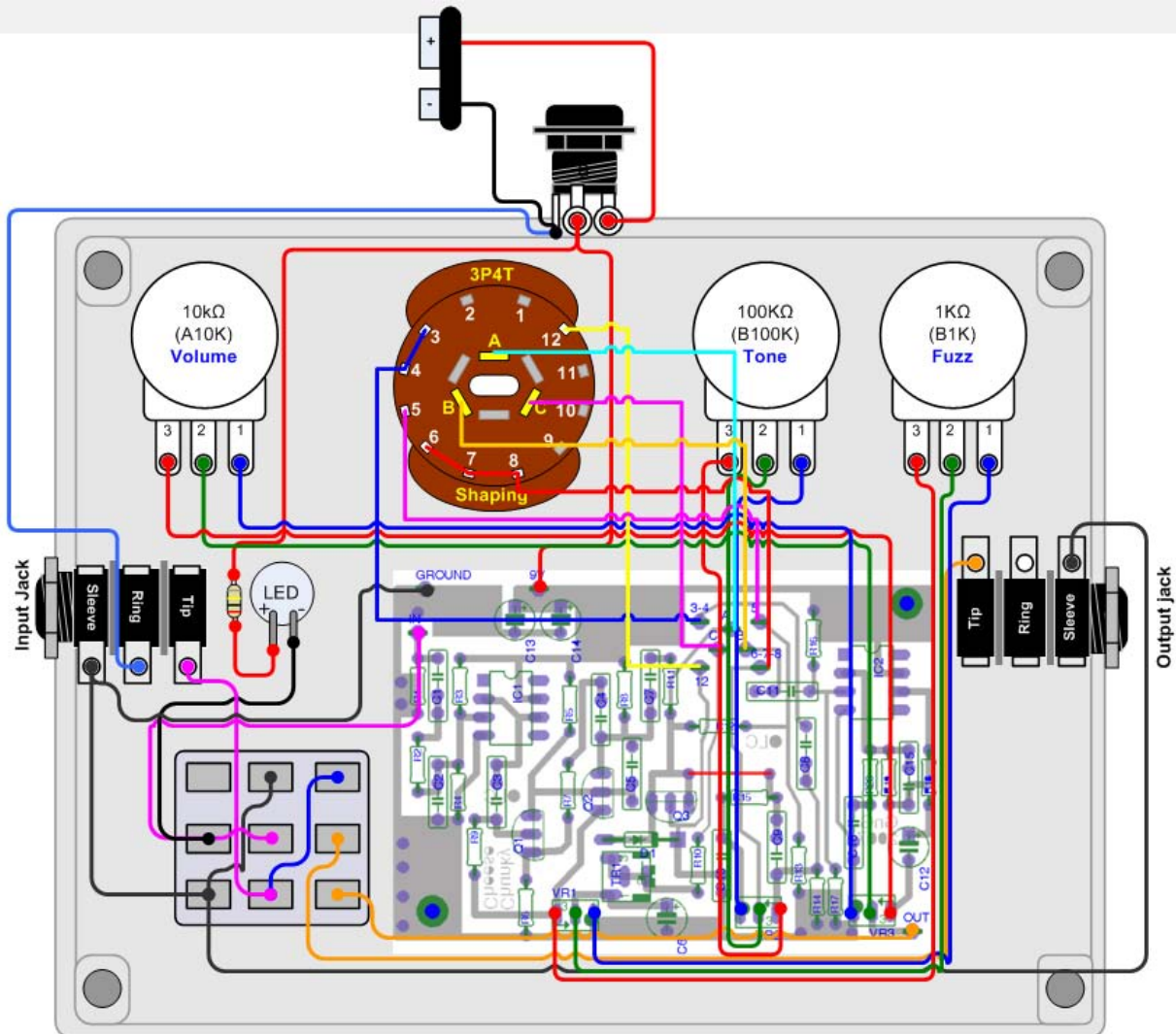

Adjusting the TR1 Trimmer

This trimmer is unlike those in other OLC kits. This one is set to your preference instead of a specified value. TR1 only affects the gating effect in the fourth position of the rotary “shaping” switch – and it’s only a fine adjustment. Turn the rotary switch to the fourth position and turn the gain control all the way up, then adjust this trimmer to fine-tune the gate effect to your preference.

Before you close the case

Before you close everything up, double-check your wiring once more. Also check that no exposed wires or other parts of the circuit are touching the cover as you put it on. Look for any wires that are loose, and be sure to tuck all wires neatly into the case so they don’t get caught between the case and the lid.

You should also install a fresh 9v battery for your initial tests—even if you plan to use an AC adaptor, you’ll want to test the battery wiring. You can use a small piece of foam wrapped around the battery to hold it in place.

Troubleshooting

If you've done everything correctly, your pedal should work just fine. However, it is pretty rare that a DIY pedal works on the first try. There are many variables, and each one has to be addressed correctly. If your pedal doesn't work on the first try, relax. This is typically how it goes. A little bit of troubleshooting and patience will get you there. This section lists things to check that address common mistakes.

The Obvious Stuff

These are the things that are so obvious that we rarely look at them first. But they may save a lot of trouble!

- Is your guitar plugged into the input jack securely?
- Is your guitar turned up?
- Is your amp plugged directly into the output of the pedal? You should go straight into your amp for testing to eliminate the possibility that other pedals or effects/wire/power are not causing the issue.
- Do you have power? Is a battery connected? Is the battery fresh? If you are using an AC adaptor, is it plugged in?

Power

- Is the pedal PCB getting power? Use your multimeter to ensure that you are getting around 9v by placing your red (+) probe on the pad that provides power (9vDC+) and any ground pad on the PCB. If you aren't getting voltage, re-check your power wiring and connections.
- Are you using an AC Adaptor? Make sure it is a 9vDC supply and that the jack is tip-negative. Make sure it is actually plugged in and functioning by using your multimeter.

Components

- Look at the PCB and the PCB Layout. Compare each value for the resistors and the capacitors. Check off each one as you verify it.
- Make sure all transistors, diodes, and ICs are oriented correctly. This is a very common problem.
- If your circuit uses polarized capacitors, make sure they are oriented correctly.
- Could an IC or transistor have wiggled out of its socket? Check all socketed components.

Wiring

- Go back and double-check your wiring. Work through the diagrams shown in each step. Print out this build guide and use your pen or pencil to place a check mark next to each wire as you verify that both ends go to the correct places.
- Visually inspect each wire to make sure that stray strands are not leading off in unwanted directions which can cause short circuits.

Soldering

- You've done a lot of soldering in this project. There is a good chance that a bad solder joint is causing problems. Use a magnifying glass to visually inspect the back (solder-side) of the PCB. Compare it against the PCB layout in this document. Are there any solder "bridges" that connect traces or lugs that shouldn't be there?
- Are there connections on the PCB that look loose or non-shiny? They may need to be re-soldered.
- Also check the soldering on all the hardware parts attached to the enclosure hardware (switches, jacks, pots, etc.) Make sure that none are loose. Use your multimeter continuity feature to check each connection.

Come Back Later

The longer you work on trouble-shooting in a single session, the less productive you become. Frustration can cloud your mind and dramatically reduce your innate problem solving skills.

Put your work away for a few hours or a day. Do something different. Play your guitar. Take a walk. Play with your kids. You'll be amazed at how productive and refreshed mind can be. Remember, building pedals is about fun and learning. So you should be having fun! ☺

Getting Help

If you've tried the troubleshooting steps and are still having problems, please visit Officially Licensed Circuits on the web at www.olcircuits.com.